

May 1995

Flexible Demodulator Option WJ-954X/FLX, WJ-9424/FLX, 869XA/FMD, /FMD-1 Option



Description

The field-installable plug-in FLX Flexible Demodulator option card for the WJ-954X FDM Demultiplexers and WJ-9424 Voice Grade Channel (VGC) Processor, and the FMD(-1) for the WJ-869XA Multichannel Receivers demodulate and decode a variety of signals. These include:

- Modem
- Voice Frequency Teletype (VFT)
- Facsimile (FAX)
- Continuous Wave (CW)
- Signaling Tones*
- Dual Tone Multifrequency (DTMF)*

A flexible output interface and X/Y display signals ease system integration. DSP techniques and programmable algorithms ensure future compatibility, and fulfill customer requirements via software upgrades only.

The FLX and FMD options demodulate most standard Modem, VFT, and FAX protocols. The FLX can also demodulate and decode common telephone network signals such as DTMF and

Features

- *Capability to demodulate a variety of VGC signals, including: Modem, FAX, VFT, CW, DTMF* & Signaling Tones**
- *User-specified demodulation for non-standard signal formats*
- *Field-installable capability via single-board plug-in option*
- *Selectable character: decodes ASCII, BAUDOT & EBCDIC*
- *Selectable synchronous binary real-time bit stream output*
- *Two analog outputs for eye diagram & constellation display generation*
- *Selectable Test Mode for functional & diagnostics testing*
- *IBM-compatible PC software*

*Not currently available with the WJ-869XA/FMD or /FMD-1.

Restricted International Distribution

WATKINS-JOHNSON COMPANY

700 Quince Orchard Road, Gaithersburg, Maryland 20878-1794
Phone: (800) WJHELPS or +(301) 948-7550
FAX: +(301) 921-9479 Email: wj.helps@wj.com Website: www.wj.com

All International sales of WJ equipment are subject to USA export license approval.

This material provides up-to-date general information on product performance and use. It is not contractual in nature, nor does it provide warranty of any kind.

signaling tones (dial, ringing, busy, call waiting, etc.). See the specifications for a comprehensive list of supported protocols. An operator can demodulate nonstandard OOK, FSK or QAM/PSK protocols by selecting specific combinations of demodulation characteristics (carrier frequency, baud rate, etc.). In a WJ-954X or WJ-9424, an operator has local control of the option via the menu-driven front panel displays. Remote control is provided via a separate interface. In a WJ-869X, a laptop computer typically provides local control. Option outputs include:

- One RS-232 port for demodulated and decoded character data
- Two analog ports for eye diagram and constellation displays on an external two-channel oscilloscope

The WJ-954X and WJ-869XA units can each have up to four option cards installed, while the WJ-9424 can have up to 30 cards. In any of these units, the option can occupy any or all designated VGC option slots. See the individual WJ-954X, WJ-9424, and WJ-869XA data sheets for other configurations.

Algorithms

The Flexible Demodulator receives a digitized 4-kHz VGC over the internal TDM bus of the WJ-954X, WJ-9424 or WJ-869XA. The bus has a maximum capacity of 240 standard 4-kHz VGCs, any one of which is selectable for input to the option.

In general, the Flexible Demodulator uses a high-speed programmable DSP chip to perform:

- FIR filtering
- Interpolation
- Symbol timing recovery
- Asynchronous resampling
- Adaptive blind equalization
- Carrier recovery
- Demodulation
- Data derandomizing
- Data decoding

The demodulation algorithm of the selected protocol may incorporate some or all of these techniques. Figures 1 and 2 illustrate the FSK and QAM algorithms.

Custom FSK demodulator configurations can successfully demodulate an FSK signal with nonstandard modulation characteristics. An operator may select custom carrier frequency, baud rate, and FM deviation, as well as mark frequency sense settings for storage and later recall. Similarly, a custom configuration can allow successful demodulation of QAM/PSK signals with nonstandard modulation characteristics. The operator may select custom carrier frequency, baud rate, signal space constellation, number of equalizer taps, differential coding, convolutional decoding, and derandomizing tap settings for memory storage and later recall. An operator can also copy parameters of a standard FSK or PSK/QAM Modem

Demodulator to create a baseline for a custom demodulator. This is especially convenient when a nonstandard protocol has characteristics similar to the standard protocol.

The demodulation characteristics for OOK signals are also operator-selectable. An operator can select custom carrier frequency, baud rate, and signal threshold-level settings for storage and subsequent recall.

The option can demodulate both FSK- and TDM-type VFT signals. In both cases, an operator can have output from one selected data channel, or simultaneous output from all data channels within the VFT signal.

In the FAX AUTO mode, the option can track a transmission through its various fallback modes and can automatically reconfigure its demodulation parameters when a fallback occurs. In the signaling mode, the FLX option can simultaneously demodulate DTMF and other tones (dial, busy, ring, call-waiting, pay-phone recognition, etc.).

Outputs

Each option card uses an individual RS-232 port to output demodulated and decoded character data. An operator can select data output as either:

1. Asynchronous ASCII or binary serial-bit stream:
 - Output data rate of 9600 or 19200 bps
 - Recovered bit stream dissected and sent out as 8-bit words (including any embedded *start*, *stop*, and *parity* bits), and framed by transmit *start*, *stop*, and *parity* bits to facilitate output to external equipment for alternate character decoding
2. Synchronous real-time binary bit stream:
 - Output data rate commensurate with the detected input symbol rate
 - Recovered bit stream transmitted by the RS-232 interface exactly as received without any transmit *start*, *stop*, and *parity* bits

An operator can select a character decoder and configure it to decode ASCII, BAUDOT, or EBCDIC characters from the incoming recovered bit stream. The RS-232 port then transmits the ASCII equivalents of these characters.

In VFT applications, an operator can have output from one selected data channel, or simultaneous outputs from all data channels within the VFT signal via the RS-232 interface. The option includes an IBM/PC-compatible software program to display demodulated VFT transmissions when the RS-232 port is connected to a PC.

In FAX applications, the option can extract both the control data (T.30 data) and image data (T.40 data) in the asynchronous binary format via the RS-232 port. Another software program is provided that accepts RS-232 control and image information from the option card, and reconstructs the FAX images on a VGA monitor. An operator can also store the FAX on a file or send it to a laser printer.

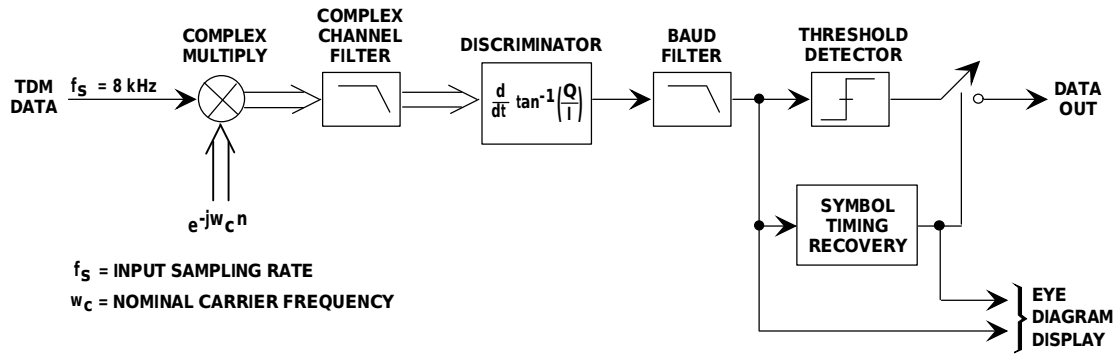

Figure 1. FSK Demodulator Algorithm

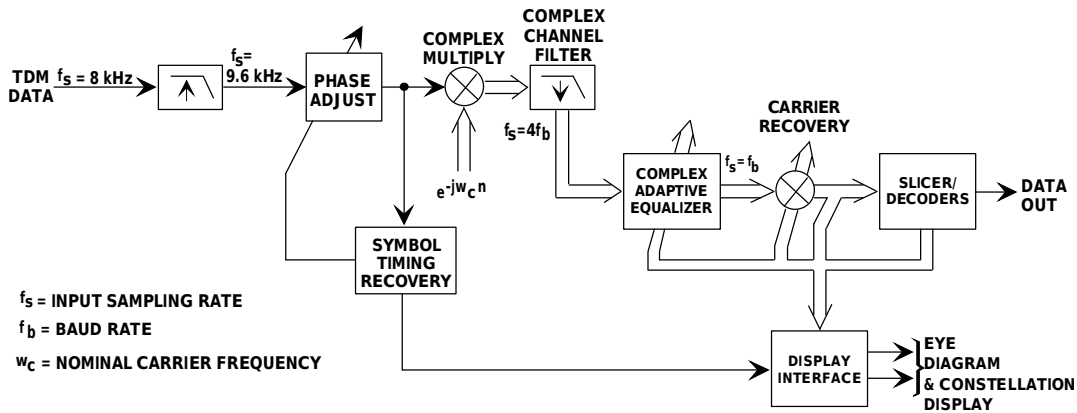

Figure 2. QAM Demodulator Algorithm

An operator can use the two analog outputs to generate eye diagrams and signal-space constellation patterns on a standard 2-channel oscilloscope. When a unit has multiple options installed, they all share the analog outputs, and the operator can select which option card drives the outputs at any one moment. Depending on the demodulation mode selected, the two outputs provide either detected data and recovered symbol timing signals for eye diagram generation, or I&Q baseband signals for constellation pattern generation. Eye diagrams and constellation displays are invaluable system integration and test tools.

Hardware

The Flexible Demodulator primarily consists of a single 3 X 5.7 inch (7.62 X 14.47 cm) printed circuit card as shown in the block diagram in Figure 3. This printed circuit card accesses a selected voice-grade channel (VGC) signal from a WJ proprietary TDM bus within the demultiplexer or receiver. A single Motorola DSP56001 processor performs all the processing on this signal. Control of the option card is accomplished by the unit's embedded control microprocessor via the DSP56001's on-chip host interface port. A standard RS-232 transmit-only interface provides the demodulated output data. Two digital-to-analog converters generate the appropriate display signals

to use with an ordinary oscilloscope with an X/Y display.

The Flexible Demodulator for WJ-954X, WJ-9424 and WJ-869XA units differ from one another only in the internal cabling of their output signals and in how they are available on each unit. Outputs of up to four WJ-954X/FLXs or WJ-869XA/FMD-1s are cabled to a single 25-pin D-type female output connector on their respective unit. The WJ-869XA/FMD uses a 9-pin D-Type as its output connector. These connectors include the RS-232 transmit data lines from all the installed Flex options, and the two analog output signals. An external cable breaks out the individual RS-232 and analog outputs into separate connectors to facilitate interfacing with external equipment.

The WJ-9424/FLX is implemented differently in that access to its data outputs depends on the selected data output option. An Individual Data Output (IDO) option provides RS-232 data outputs for 12 FLXs on a single 25-pin D-style connector. An operator can install additional IDOs to handle more than 12 FLXs. Alternatively, an operator can install one of a variety of output data formatter options to combine all demodulated data onto a single high-speed standard interface.

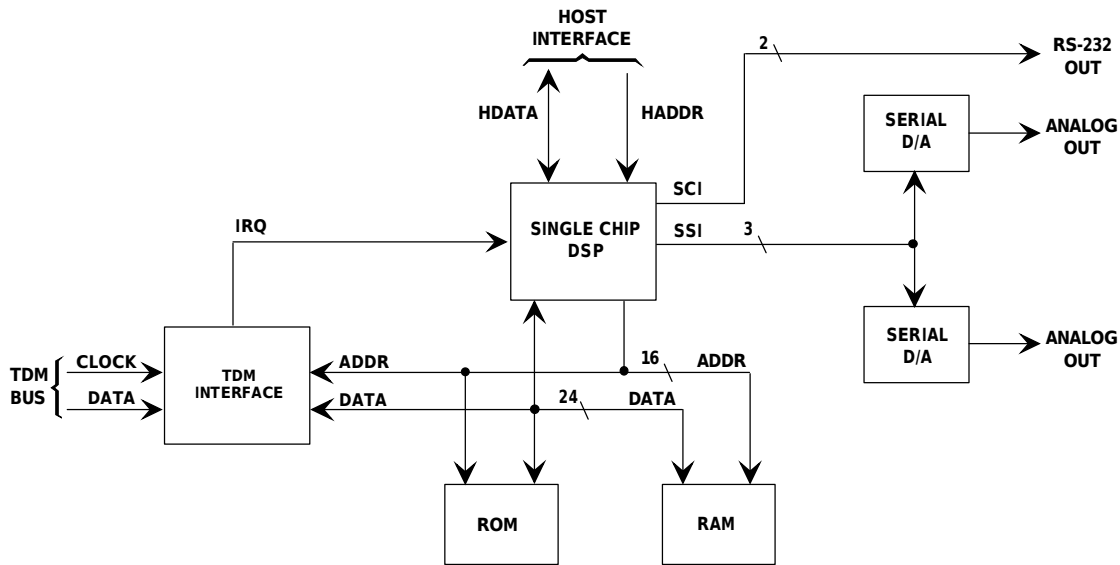

Figure 3. Block Diagram of the Option Card

Specifications

Demodulation Modes

Modem (FSK)	Bell 103, 113, 202C, V.21, V.23, V.23 ALT, User-programmable FSK
Modem (QAM)	Bell 201B, 208A, 212A, V.22, V.22 ALT, V.22bis, V.26A, V.26B, V.26bis, V.26bis ALT, V.26ter, V.26ter ALT, V.27, V.27bis, V.27bis ALT, V.27ter, V.27ter ALT, V.29, V.29 ALT A, V.29 ALT B, V.32*, V.32 ALT*, V.33*, V.33 ALT*, User-programmable QAM
VFT (FSK)	R.35, R.35 ALT, R.35bis, R.37, R.37 ALT, R.38A, R.38B, R.39, R.39 ALT 1, R.39 ALT 2
VFT (TDM)	R.101A, (50 & 75 baud outputs), R.101B (50, 75, 100, 150, 200 & 300 baud outputs) Demultiplexing applied to following modems: V.26A, V.26B, V.26bis, V.26ter, V.27bis ALT, V.27ter ALT, V.29, V.29 ALT A & V.29 ALT B
FAX	Group 3; 9600, 7200, 4800 & 2400 baud with automatic fallback tracking
Signaling*	Q.23 (DTMF) & Q.35 (Dial tone, Ringing, Busy, Call Wait, etc.)
CW	User-programmable OOK

Output Characteristics

Digital	Single RS-232 transmit-only serial data at 9.6 or 19.2 kbps, or synchronous serial bit stream commensurate with input data rate (operator-selectable)
Analog	I/Q baseband used for constellation display or data & synchronization signals used for eye diagram display

Physical Characteristics

Operating Temperature	0 to 50°C
Power	3 W, max
Size	3 x 5.7-inch PC card (7.62 x 14.48 cm)

*Not currently available with the WJ-869XA/FMD or /FMD-1